

Model: SP-LP0511

Ceiling Exhaust Fan

Standard Construction Features:

Galvanized steel housing - Outlet duct collar with integral back draft damper -
 Forward curved wheel - Plug type disconnect - Adjustable mounting brackets -
 Sound absorbing insulation - EC Motor

Selected Options & Accessories:

Constant CFM EC Motor rated for continuous use
 Motor with Thermal Overload
 Motor with 40 Degree C Ambient Temperature
 Oval Duct Connection
 Affixed non-adjustable mounting bracket
 Energy Star Certified
 ETL Listed
 Standard Grille
 Polypropylene Wheel Material
 Can Be Used to Comply with: ASHRAE 62.2, California Title 24, and Washington State Energy Code

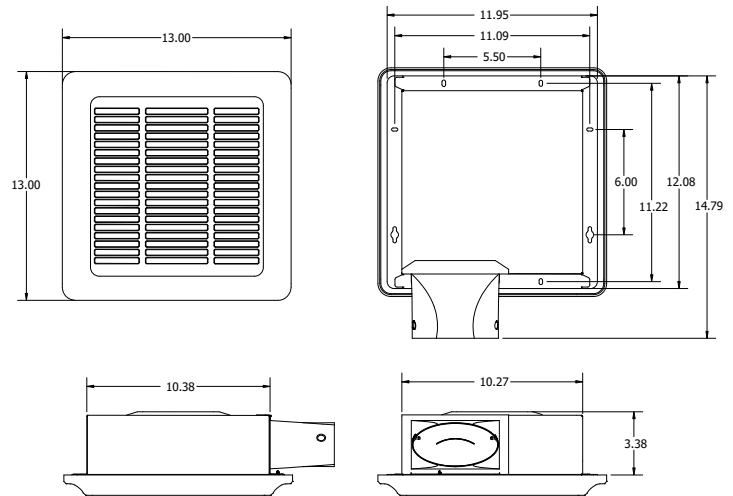

Dimensional	
Quantity	10
Weight w/o Acc's (lb)	8
Weight w/ Acc's (lb)	8

Performance	
Requested Volume (CFM)	110
Actual Volume (CFM)	110
Total External SP (in. wg)	0.25
Fan RPM	939
* FLA (A)	0.29
Elevation (ft)	5,138
Airstream Temp.(F)	70
Air Density (lb/ft3)	0.062
Sones	2.5

Motor	
Motor Mounted	Yes
** FEP Input Power (kW)	0.00
Voltage/Cycle/Phase	115/60/1
Enclosure	TEAO

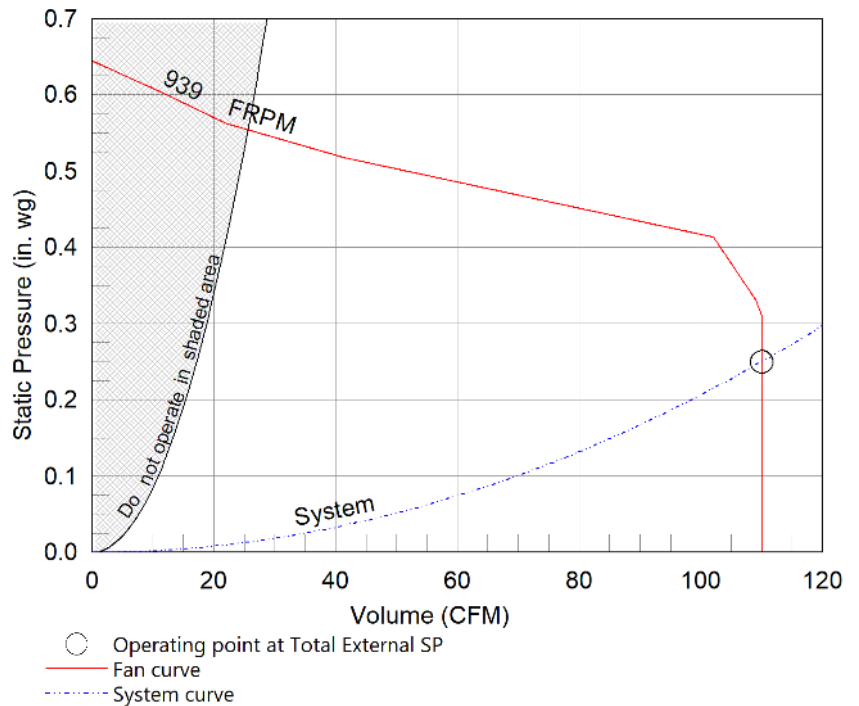

Notes:

All dimensions shown are in units of in.
 *FLA is approximate and will vary slightly with the motor.
 Sones - calculated using AMCA 301 at 5 ft
 ** Wattage is approximate and may vary between motors.
 * HVI certified for .1", .25", and .375" of SP.

