



1900 Series Pump | Submittal Data

Submittal No: 301-243 | Model: 1915 | RPM: 1760 | Effective: May 30, 2024 | Supersedes: August 2, 2023

JOB: _____

REPRESENTATIVE: _____

ENGINEER: _____

CONTRACTOR: _____

PRODUCT DATA

ITEM NO. _____ MODEL NO. 1915

IMPELLER DIAMETER _____ HORSEPOWER _____

GPM _____ RPM 1760 VOLTAGE _____

HEAD/FT _____ WEIGHT _____

NSF 61 CERTIFIED YES NO

DIMENSIONS

Model No. | 1915

Flange Size (Suction x Discharge) | 1 1/2 (38)

HORSEPOWER (KW)	1/3 (0.25)	1/2 (0.37)	3/4 (0.56)	1 (0.75)	1.5 (1.12)
PUMP WEIGHT LBS (KG)	85 (39)	89 (40)	90 (41)	100 (45)	112 (51)
A	3.13 (79)				
B	14.00 (356)	15.00 (381)	16.00 (406)		
C	13.50 (343)				
D	16.13 (410)				
E	5.15 (131)				
F	9.75 (248)				

English dimensions are in inches. Metric dimensions are in millimeters.
Metric data is presented in (). Do not use for construction purposes unless certified.

Configuration	DOE Basic Model Number	PEI Value		Energy Rating
		PEI _d	N/A	
Bare Pump	N/A	PEI _d	N/A	N/A
Pump + Motor	N/A	PEI _d	N/A	N/A

N/A=NOT WITHIN DOE SCOPE

SPECIFICATIONS

MOTORS

1760 RPM, Three Phase 208/230/460V, 60 Hz, Nema 56 C Frame Motors. Also available in Single Phase 115/208/230V. Motors are sealed ball bearing design, and require no maintenance.

BODY

Cast iron with in-line flanged connections. Also available in optional all Stainless Steel (304). Companion flanges included with the pump. NSF61 All-SS models are also available.

IMPELLER

One Piece Cast Stainless Steel (304), Closed, Dynamically Balanced Impeller.

DRIVE

Close Coupled Direct Driven Pump.

SHAFT

416 Stainless Steel Shaft.

MECHANICAL SEAL

J. Crane Type 21 with carbon rotating element and ceramic stationary seat, with a maximum operating temperature of 250° F (121° C) furnished as standard. Optional "Sealide C" with silicon carbide rotating element and silicon carbide stationary seat is also available for systems with aggressive/glycol fluids, with a maximum operating temperature of 300° F (149° C).

WORKING PRESSURE

175 PSI (1207 kPa) in accordance with ASA B16.1.

VARIABLE FREQUENCY DRIVE RECOMMENDATIONS

Pump Turn Down Ratio = 4:1

Recommended Minimum Drive Frequency = 15 Hz

NOTE: Pump flanges are tapped for gauges.

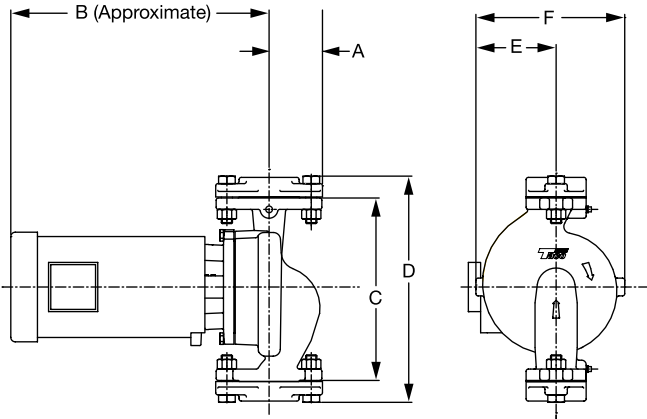



MODEL 1915
1900 SERIES

1760 RPM

CURVE NO. 875
Min. Imp. Dia. 4.7
Size 1 1/2"

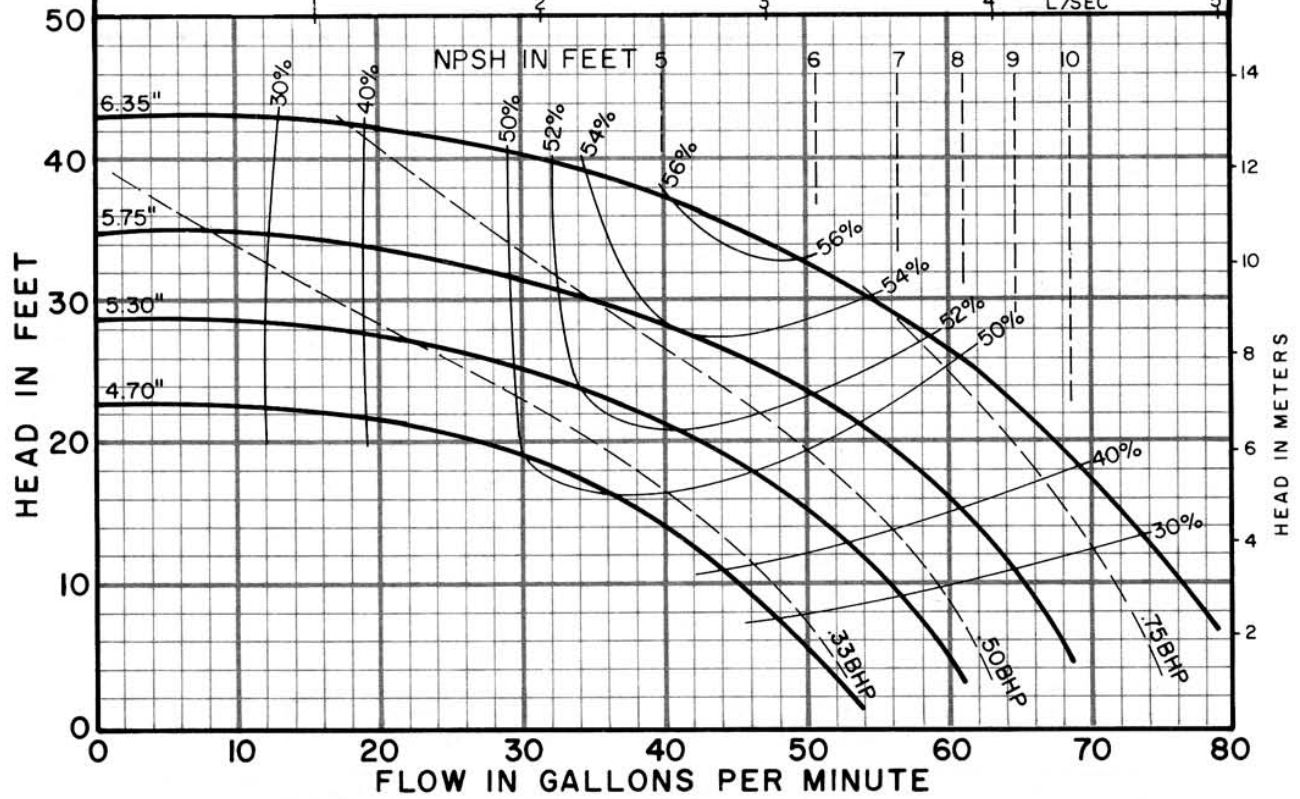

COMMENTS